



## Product Data Sheet

### **IntegraPac™ Ultrafiltration Skid** With IP-77 or IPD-77

#### **Description**

The IntegraPac™ skid with IP-77 or IPD-77 modules from DuPont Water Solutions is a pre-engineered, standardized skid design consisting of IntegraPac™ ultrafiltration modules, auxiliary parts and piping. It is designed to significantly streamline design, assembly and installation, making possible lower skid costs, reduced engineering design costs, easy assembly, smaller footprint and shortened delivery schedule. Features include:

- The IP-77 and IPD-77 skids are tested and certified by NSF International under NSF/ANSI Standard 61 ensuring safe use in drinking water applications
- NSF/ANSI Standard 419 for Public Drinking Water Equipment on module IPD-77
- Direct coupling of modules eliminates ancillary piping, saving costs and reducing footprint
- Modular and scalable for design across a wide range of flow rates
- Materials of construction selected for corrosion resistance and chemical compatibility
- Shipped unassembled to lower transportation cost and help prevent damage in transit
- Standardized and pre-fabricated components eliminates measuring, cutting, gluing and welding
- Easily accessible for physical inspection or replacement at end of life
- Operator-friendly transparent filtrate elbow designed and located for easy visual integrity inspection
- High pressure rating to enable direct feed to reverse osmosis feed pumps



## Typical Properties

No. of Modules	IntegraPac™ Skid	Membrane Area		Flow @ 65 lmh (38 gfd)		Length (L)		Width (W)		Height (H)		Weight, dry (incl. modules)		Weight, filled (incl. modules)		Hold-Up Volume	
		m <sup>2</sup>	ft <sup>2</sup>	m <sup>3</sup> /h	gpm	mm	ft	mm	ft	mm	ft	kg	lbs	kg	lbs	m <sup>3</sup>	US gal
6	IP & IPD- 77-06	462	4974	30	132	1241	4.1	764	2.51	2875	9.43	496	1093	840	1852	0.32	84.0
8	IP & IPD- 77-08	616	6632	40	176	1604	5.3	764	2.51	2875	9.43	644	1420	1102	2429	0.42	112.0
10	IP & IPD- 77-10	770	8290	50	220	1967	6.5	764	2.51	2875	9.43	791	1744	1364	3007	0.53	140.0
12	IP & IPD- 77-12	924	9948	60	264	2330	7.6	764	2.51	2875	9.43	939	2070	1626	3585	0.64	168.0
14	IP & IPD- 77-14	1078	11606	70	309	2693	8.8	764	2.51	2875	9.43	1091	2405	1893	4173	0.74	196.0
16	IP & IPD- 77-16	1232	13264	80	353	3056	10.0	764	2.51	2875	9.43	1249	2754	2165	4773	0.85	224.0
18	IP & IPD- 77-18	1386	14922	90	397	3419	11.2	764	2.51	2875	9.43	1401	3089	2432	5362	0.95	252.0
20	IP & IPD- 77-20	1540	16580	100	441	3782	12.4	764	2.51	2875	9.43	1554	3426	2699	5950	1.06	280.0
22	IP & IPD- 77-22	1694	18238	110	485	4145	13.6	764	2.51	2875	9.43	1706	3761	2966	6539	1.17	308.0

## Dimensions

Example: 2x7  
IntegraPac™ IP & IPD-77-14 Arrangement

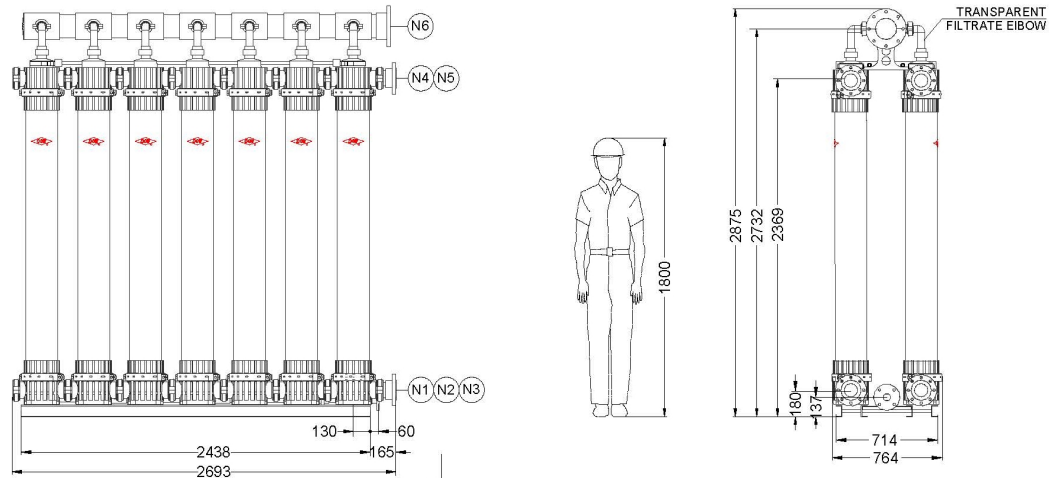

## Suggested Operating Conditions

	SI Units	US Units
Filtrate Flux (25°C)	40-90 l/m <sup>2</sup> /hr	24 - 53 gfd
Temperature	1-40°C	34-104°F
Maximum Inlet Module Pressure (20°C)	6.25 bar	90.65 psi
Maximum Inlet Module Pressure (40°C)	4.75 bar	68.89 psi
Maximum Operating TMP	2.1 bar	30.5 psi
Maximum Operating Air Scour Flow	12 nm <sup>3</sup> /hr	7.1 scfm
Maximum Backwash Pressure	2.5 bar	36 psi
Operating pH		2 – 11
Maximum NaOCl		2,000 mg/L
Maximum Particle Size		300 µm
Flow Configuration		Outside in, dead end flow
Expected Filtrate Turbidity		≤ 0.1 NTU
Expected Filtrate SDI		≤ 2.5

## Important Information

Proper start-up of an ultrafiltration system is essential to prepare the membranes for operating service and to prevent membrane damage. Following the proper start-up sequence also helps ensure that system operating parameters conform to design specifications so that system water quality and productivity goals can be achieved.

Before initiating system start-up procedures, membrane pretreatment, installation of the membrane modules, instrument calibration and other system checks should be completed.

Please refer to the Ultrafiltration Technical Manual (Form No. 45-D00874-en).

## Operation Guidelines

Avoid any abrupt pressure variations during start-up, shutdown, cleaning or other sequences to prevent possible membrane damage. Flush the ultrafiltration system to remove shipping solution prior to start-up. Remove residual air from the system prior to start-up. Manually start the equipment. Depending on the application, filtrate obtained from initial operations should be discarded.

Please refer to the Ultrafiltration Technical Manual (Form No. 45-D00874-en).

## General Information

- If operating limits and guidelines given in this bulletin are not strictly followed, the limited warranty will be null and void.
- To control biological growth during extended system shutdowns, it is recommended that storage solution be injected into the membrane modules.

Please refer to the Ultrafiltration Technical Manual (Form No. 45-D00874-en) and Technical Service Bulletins.

## Product Stewardship

DuPont has a fundamental concern for all who make, distribute, and use its products, and for the environment in which we live. This concern is the basis for our product stewardship philosophy by which we assess the safety, health, and environmental information on our products and then take appropriate steps to protect employee and public health and our environment. The success of our product stewardship program rests with each and every individual involved with DuPont products—from the initial concept and research, to manufacture, use, sale, disposal, and recycle of each product.

## Customer Notice

DuPont strongly encourages its customers to review both their manufacturing processes and their applications of DuPont products from the standpoint of human health and environmental quality to ensure that DuPont products are not used in ways for which they are not intended or tested. DuPont personnel are available to answer your questions and to provide reasonable technical support. DuPont product literature, including safety data sheets, should be consulted prior to use of DuPont products. Current safety data sheets are available from DuPont.

Please be aware of the following:

- The use of this product in and of itself does not necessarily guarantee the removal of cysts and pathogens from water. Effective cyst and pathogen reduction is dependent on the complete system design and on the operation and maintenance of the system.

## Regulatory Note

NSF/ANSI 61 and 419 certified drinking water modules require specific conditioning procedures prior to producing potable water. Please refer to the Ultrafiltration Technical Manual (Form No. 45-D00874-en) flushing section for specific procedures. Drinking water modules may be subjected to additional regulatory restrictions in some countries. Please check local regulatory guidelines and application status before use and sales.

All information set forth herein is for informational purposes only. This information is general information and may differ from that based on actual conditions. Customer is responsible for determining whether products and the information in this document are appropriate for Customer's use and for ensuring that Customer's workplace and disposal practices are in compliance with applicable laws and other government enactments. The product shown in this literature may not be available for sale and/or available in all geographies where DuPont is represented. The claims made may not have been approved for use in all countries. Please note that physical properties may vary depending on certain conditions and while operating conditions stated in this document are intended to lengthen product lifespan and/or improve product performance, it will ultimately depend on actual circumstances and is in no event a guarantee of achieving any specific results. DuPont assumes no obligation or liability for the information in this document. References to "DuPont" or the "Company" mean the DuPont legal entity selling the products to Customer unless otherwise expressly noted. NO WARRANTIES ARE GIVEN; ALL IMPLIED WARRANTIES OF MERCHANTABILITY OR FITNESS FOR A PARTICULAR PURPOSE ARE EXPRESSLY EXCLUDED. No freedom from infringement of any patent or trademark owned by DuPont or others is to be inferred.

DuPont™, the DuPont Oval Logo, and all trademarks and service marks denoted with ™, ℠ or ® are owned by affiliates of DuPont de Nemours Inc. unless otherwise noted. © 2020 DuPont.

